

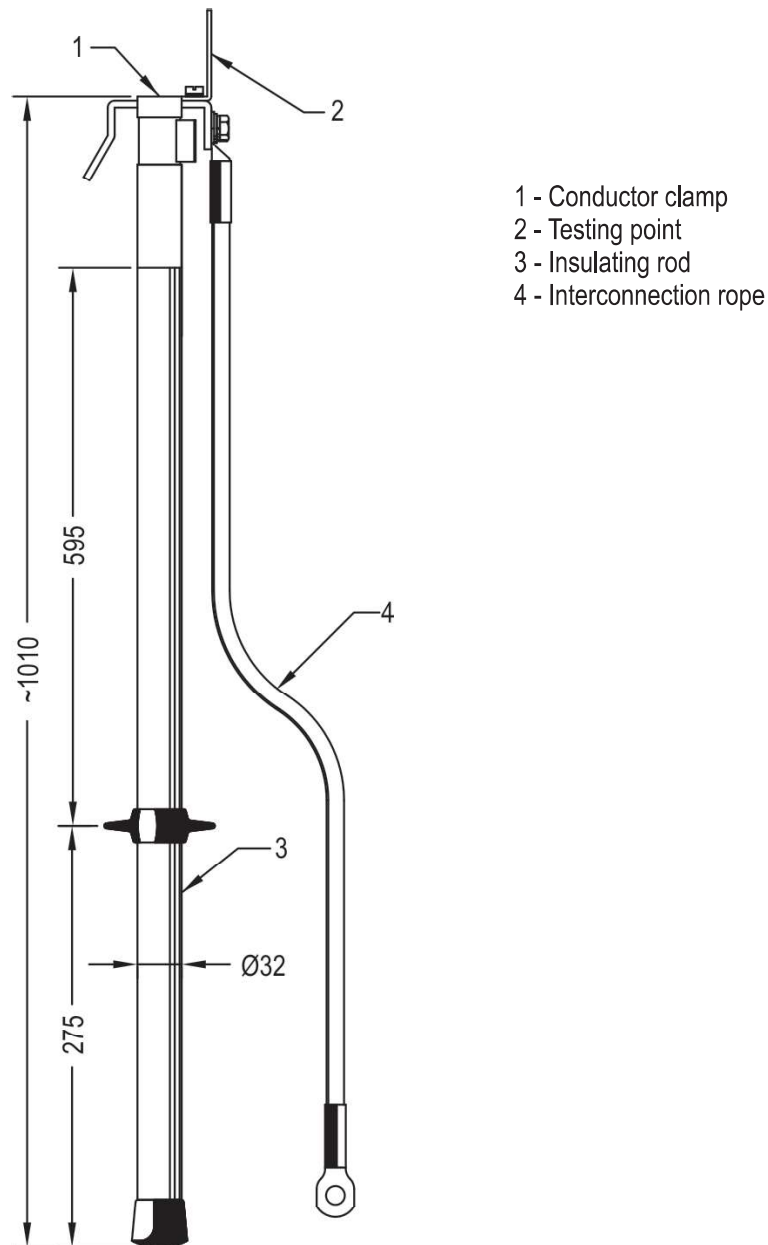

SHUNTING SET BS

type 153 025

Shunting set BS is designed to create safety conductive connection of conductive parts of insulated working platform with contact line or to create safety switch-over of electric split of the contact line.



SPECIFICATION

Attachable to:

- trolley conductor 80-150 mm²
- satisfy TNŽ 359708, ČSN EN 61230

Nominal voltage of device	27,5 kV
Current capacity	800 A/10 min
Short-circuit resistance	10 kA/ 1 sec; 5 kA/ 5 sec
Rope's cross-section	50 mm ²
Rope's length	1 350 mm
Weight	2,1 kg